

THRUSHES EAT INSECTS

Over Thirty Per Cent of Vegetable Food Is Wild Berries.

Domestic Fruits Are Eaten So Sparingly by the Birds as to Be of No Economic Importance—Devours Many Harmful Beetles.

(By E. L. BEALL.)
The thrushes are pronounced ground feeders, and may often be seen picking small fruit that has fallen to the ground. The vegetable portion of their food (40.72 per cent) is largely composed of fruit, which constitutes over 24 per cent of the total food. Of this 39.88 per cent is made up of wild berries, which outweigh the domestic varieties with every species. In all, 24 species of wild fruits or berries were identified in the stomachs of these birds, although it is not always practicable to identify such material unless seeds or some other characteristic parts are present. As this is not



Wood Thrush.

often the case, a considerable portion of the stomach contents must be pronounced "fruit pulp" without further identification; thus probably many more species are eaten than are recorded. Moreover, in the case of some fruits it is not possible to distinguish species by the seeds, so that many species go unrecognized except as to genus. Domestic fruits are eaten so sparingly by the thrushes as to be of no economic importance.

The wood thrush is distributed over the eastern part of the United States wherever suitable conditions are found. It is a lover of open groves and bushy pastures, and may be found along little traveled roads and near low bushy swamps.

For the investigation of the food habits of the wood thrush 171 stomachs were available.

Beetles, collectively (20.40 per cent) constitute the largest item of animal food. Of these, 2.23 per cent are the predaceous ground beetles generally considered useful. The remainder belong to several more or less harmful families, of which the May-beetle family amount to 10.17 per cent.

More than nine-tenths of the vegetable food of the wood thrush can be included in a single item—fruit. Cultivated fruit, or what was thought to be such, was found in stomachs taken from June to September, inclusive. It was eaten regularly and moderately, and the total for the season was 3.74 per cent of the whole food. Wild



Hermit Thrush.

fruits or berries of 22 species were found in 72 stomachs, distributed through every month of the bird's stay at the North.

The hermit thrush inhabits the eastern states in winter as far north as Massachusetts and breeds from the mountains of Maryland and Pennsylvania and from northern Michigan and central Minnesota northward to Alaska.

Inquiry into the food habits of this bird covered 551 stomachs, collected in 29 states, the District of Columbia and Canada, and representing every month of the year. In the primary analysis the food was found to consist of 64.51 per cent of animal matter and 35.49 per cent of vegetable. The former is mostly composed of insects, with some spiders, while the latter is largely fruit, chiefly wild species. Beetles constitute 15.13 per cent of the food. The ants destroyed—12.46 per cent of the food—keep up the reputation of thrushes as ant eaters. Caterpillars, eaten in every month and mostly in goodly quantities, appear to be a favorite food of the hermit thrush. Flies comprise 3.02 per cent of the food of this bird.

GOOD ROADS

IMPROVE ROADS BY DRAINAGE

One of the Most Important Matters to Be Considered in Construction of Public Highways.

(By E. L. GATES, Illinois.)
When it comes to building roads there are a good many problems to solve and not easy ones at that. Riding along in an auto it is easy enough to say when you strike a smooth stretch, "this is fine," and turn on a little more gas. But when you hit a mudhole and ruts you may get your foot on the wrong pedal and the road commission catches it.

It takes labor, time, good material and money to have good roads. Everyone wants the roads, so we will all have to work and spend some of our time and money and boost for better roads.

One of the things most needed is better drainage for the roads as well as for the farms and at this time we will confine this article to the subject of drainage.

Drainage is the most important matter to be considered in the construction of roads. Drainage alone will often change a bad road into a good one while the best stone road may be destroyed from a lack of proper drainage.

There are three systems of drainage that we can use to advantage, and these are underdrainage, side ditches and surface drainage.

Where water stands on a road underdrainage without any grading is better than grading without underdrainage. Underdrainage is not to remove simply the surface water but its greatest help is to lower the water level in the soil.

The action of the sun and wind will finally dry the surface of the road but if the foundation is wet and soft the wheels will wear ruts and these get filled with water during the first rains and the road becomes a sticky mass.

An undrained soil is a poor foundation upon which to build roads as well as anything else. When frost is leaving the ground the thawing is quite as much from the bottom as from the top. If underdrainage is provided the water is immediately removed.

The best and cheapest method to secure underdrainage is to lay a line of farm drain tile on one or both sides of the road. The new road law gives the highway commissioners power to contract with adjoining property owners to lay larger tile than is necessary to drain the road and to permit the contracting parties to drain their lands. This helps the roads and at the same time is a great benefit to the adjoining land.

Side ditches are necessary to all roads but no road can be maintained with the ditch holding the water under the road.

Side ditches are necessary to all roads but no road can be maintained with the ditch holding the water under the road.

Side ditches are necessary to all roads but no road can be maintained with the ditch holding the water under the road.

Side ditches are necessary to all roads but no road can be maintained with the ditch holding the water under the road.

Side ditches are necessary to all roads but no road can be maintained with the ditch holding the water under the road.

Side ditches are necessary to all roads but no road can be maintained with the ditch holding the water under the road.

Side ditches are necessary to all roads but no road can be maintained with the ditch holding the water under the road.

Side ditches are necessary to all roads but no road can be maintained with the ditch holding the water under the road.

Side ditches are necessary to all roads but no road can be maintained with the ditch holding the water under the road.

Side ditches are necessary to all roads but no road can be maintained with the ditch holding the water under the road.

Side ditches are necessary to all roads but no road can be maintained with the ditch holding the water under the road.

Side ditches are necessary to all roads but no road can be maintained with the ditch holding the water under the road.

Side ditches are necessary to all roads but no road can be maintained with the ditch holding the water under the road.

Side ditches are necessary to all roads but no road can be maintained with the ditch holding the water under the road.

Side ditches are necessary to all roads but no road can be maintained with the ditch holding the water under the road.

Side ditches are necessary to all roads but no road can be maintained with the ditch holding the water under the road.

Side ditches are necessary to all roads but no road can be maintained with the ditch holding the water under the road.

Side ditches are necessary to all roads but no road can be maintained with the ditch holding the water under the road.

Side ditches are necessary to all roads but no road can be maintained with the ditch holding the water under the road.

Side ditches are necessary to all roads but no road can be maintained with the ditch holding the water under the road.

Side ditches are necessary to all roads but no road can be maintained with the ditch holding the water under the road.

Side ditches are necessary to all roads but no road can be maintained with the ditch holding the water under the road.

MASONS TO ELECT OFFICERS

At the regular communication of Brevard Masons Friday night the annual election of officers will be made and for this event a good attendance is urged.

Always at Your Service for Printing Needs!

Is there something you need in the following list?

- Birth Announcements
- Wedding Stationery
- Envelope Inclosures
- Sale Bills
- Head Bills
- Price Lists
- Admission Tickets
- Business Cards
- Window Cards
- Time Cards
- Letter Heads
- Note Heads
- Envelopes
- Bill Heads
- Calling Cards
- Leaflets
- Statements
- Stock Tickets
- Key Tickets
- Shipping Tags
- Announcements
- Briefs
- Notes
- Coupons
- Pamphlets
- Catalogues
- Circulars
- Posters
- Blotters
- Invitations
- Folders
- Cheques
- Blankets
- Notices
- Labels
- Legal Planks
- Menu Cards
- Flancards
- Builders
- Post Cards
- Programs
- Receipts

Prompt, careful and efficient attention given to every detail

Don't Send Your Order Out of Town Until You See What We Can Do

Quality Print Shop

Telephone No. 7

SOUTHERN RAILWAY COMPANY

Transylvania Division

Effective September 26, 1915.

"Schedule figures published as information. Not guaranteed."

No. 6 No. 8 Eastern Time No. 5 No. 7

4 10 10 30	Ashville	11 15 8 10
5 30 11 30	Hendersonville	9 50 5 06
5 45 11 45	Yale	9 35 4 39
5 50 11 50	Horse Shoe	9 30 4 34
5 53 11 53	Cannon	9 27 4 31
5 59 11 59	Flovah	9 21 4 25
6 05 12 05	Banatare	9 15 4 19
6 11 12 11	Pontrose	9 09 4 12
6 20 12 20	Davidson River	9 00 4 04
6 23 12 23	Pisgah Forest	8 57 4 01
6 30 12 30	BREVARD	8 50 3 55
6 36 12 36	Selma	8 43 3 48
6 53 12 53	Cherryfield	8 27 3 35
6 56 12 56	Calvert	8 21 3 32
7 00 1 01	Rosman	8 20 3 29
7 12 1 14	Quebec	8 08 3 18
7 30 1 35	Lake Toxaway	7 50 3 00

West Hendersonville and Davis are flag stops for Nos. 5, 6, 7, and 8.
Galloways and Reids are flag stops for Nos. 5 and 6.
J. H. Woods, Div. Pass. Agent, S. C. VA. Div., Ticket Agent.

MANGER TO CROSS APPRECIATED

"The Manger to the Cross" picture shown at the Auditorium under the auspices of the Methodist church was seen and appreciated by a good house Wednesday afternoon and night.

The spectators entered into the spirit of the picture and unusual quiet for a picture show prevailed throughout the solemn drama, purporting to picture the life of Christ.

DON'T WAIT

Take Advantage of a Waynesville Citizen's Experience

When the back begins to ache,

Don't wait until backache becomes chronic;

"Till kidney troubles develop;

"Till urinary troubles destroy night's rest.

Profit by a Waynesville citizen's experience.

J. E. McHaffy, prop. of grocery, Killian St., Waynesville, N. C., says: "I have used Dean's Kidney Pills and I know they are a fine medicine for kidney trouble and backache. I have no hesitation in recommending them to others who suffer in that way."

Price 50c. at all dealers. Don't simply ask for a kidney remedy—get Dean's Kidney Pills—the same that Mrs. McHaffy had. Foster-Milburn Co., Props., Buffalo, N. Y.

To Cure Hiccoughs.

To cure hiccoughs, fill a glass with water, draw a deep breath through the mouth, take a mouthful of water, hold the glass before you above your head, raise your eyes so that they can see the bottom of the glass without throwing your head back, swallow the water and then breath out slowly through the mouth.

IN THE SOUTHERN COUNTRIES

Easter Celebrations Have Their Own Arrangements, Which Reflect the People's Ideas.

Throughout Cuba and Central America, the presence of soldiers dignifies the clumsy quaintness of the Easter celebrations. Crowds gather early in the plazas to watch the life-sized, waxen image of Jesus borne out of the cathedral on a high-draped platform. Acolytes, bearing censers, precede it, and behind it trail clouds of priests, bands, and flags. The procession moves slowly through a main thoroughfare until it meets a second figure, resplendent in blue paint, curls, and finery. There is a pause as the two figures confront each other. Then the second—Mary Magdalene—is turned laboriously about and gallops away with its joyful news. It encounters a third figure, painted yellow and decked with gold, as belts the Latin-American conception of the Virgin Mary. With the gilded figure leading, the two Marys trot back through the crowded streets to the first image. As the three meet, their draped platform forms tip forward in solemn, silent bows, while thousands of awed believers watch in silence. Forming into line, the three images are borne back to the cathedral, the troops fire a salvo, and the Easter services begin.

Responsibility Surrendered.

"Your wife is an enthusiastic advocate of woman suffrage." "Yes," replied Mr. Meekton. "And I'm glad of it. She's going to take her turn at letting me ask irrelevant questions, while she tries to explain what's being done in politics."

The End of All Things.

Man with Paper—"Here's a preacher in Syracuse, N. Y., who declares that the time will come when there will be no liars in the world." Pessimist—"Well, the world is due to end some day."—Canadian Courier.

SYLVAN VALLEY NEWS HONOR ROLL FOR PAST TWO WEEKS

New Subscribers

E. K. McCrary	Cedar Mountain
W. H. Hinkle	Sapphire
W. H. James	Greer, S. C.
R. J. Alexander	Sapphire
T. F. Galloway	Rosman
W. C. Hunt	Brevard
Louis White (Col.)	Brevard
A. V. Lyday	Wake Forest
S. F. Wasson	Pisgah Forest
Mrs. Harvey Rogers	Brevard
Miss Loma Squires	Brevard
Mrs. Joseph Dunn	Cedar Mt.
R. W. Lee	Brevard R2
Ulysses Thrift	Sapphire
Jim Monteith	Stackhouse
J. A. Nelson	Stackhouse
Surgeon Lebetter Campobello	S. C. R2

Renewals

Joseph A. Miller, sr.	Brevard
D. M. Sherrill	Pisgah Forest R2
Miss Addie Thomas	Pisgah Forest
G. M. Justus	Brevard R1
P. L. Gallamore	Brevard
Neal Hamilton	Brevard
J. W. Smith	Brevard
Mrs. W. M. Shipman	Etowah
C. F. Baldwin	Brevard
Mrs. H. P. Moore	Pisgah Forest
C. L. Saunders	Lake Toxaway
A. A. Miller	Oakland
V. D. Peck	Brevard

YOUR NAME

Is it on our subscription list?

We will guarantee you full value

FOR YOUR MONEY

Rent an UNDERWOOD Typewriter

Its simplicity of construction and ease of operation have made this machine the choice of the greatest typists and largest corporations.

The "Just as good as the Underwood" argument, advanced for the sale of other typewriters, sums up all the proof of Underwood supremacy.

THE MACHINE YOU WILL EVENTUALLY BUY

Brevard Hardware Company

Brevard, North Carolina

INTERNATIONAL HARVESTER MACHINES

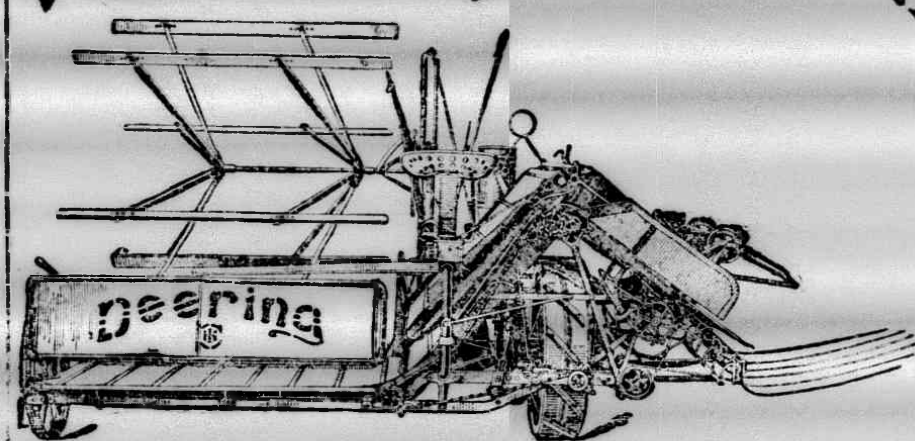

Deering Mower Assets

A THOROUGHLY dependable mower is a big asset at haying time. A good mower should be able to cut grass in any condition satisfactorily, and in this respect the Deering New Ideal is a pronounced leader.

The flexible movement of the cutter bar which permits close cutting over rough ground, the one-piece main frame with all holes drilled in one operation to secure perfect alignment of parts, the covered gears and the special quality steel ball and roller bearings, etc.

Still another point—the ledger plate on the Deering mower extends the full length of the cutting surface of the guard, giving the advantage of a complete shear cut, whether the knife section is old or new. This does away with all clogging of the grass between the knife section and the rear end of the ledger plate.

Drop in and see us and we will show you the mower in detail.

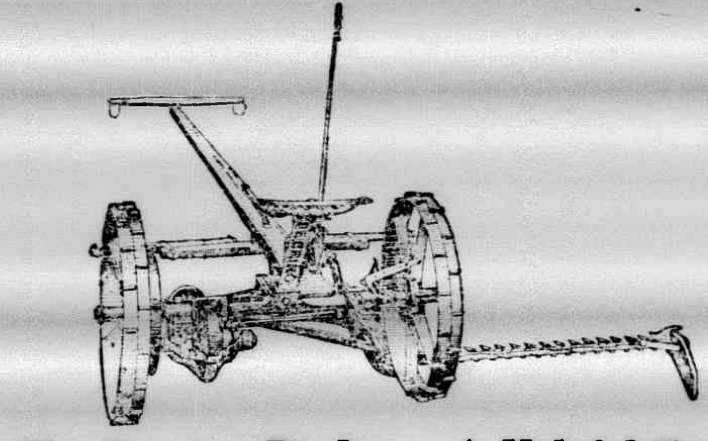

The Deering Binder—A Helpful Friend

NO reasonable man ever turns down an old friend. Also, when a friend has proved himself particularly helpful and dependable, you have no hesitation in recommending him to other people in need of a friend.

The Deering binder has proved itself a good friend to so large a number of farmers in this neighborhood, and has proved its helpfulness through so many years of successful service, that it has a good claim to consideration from any farmer who has any idea of buying a binder this year.

Because of its reputation and years of service, we recommend the Deering binder to every grain-growing farmer.

Don't buy a binder until you have seen the Deering, until you know its record, and until we have had a chance to present all its good points to you personally. Come in and see us.

Don't order

C. DOYLE

Brevard, N. C.