

# Wataugans At Work



J. C. Downs of Route 3, Boone, has been employed by the Town House Restaurant for four years. He and Mrs. Downs have one son, Jimmy, who is 9 years old and in the fourth grade. A veteran of World War II, during which he served in the Pacific Theater, Downs is retired from the U. S. Navy, having served 21 years in that branch of the service. (Staff photo)

# Farmers Asked To Take Note Of Labor Laws

Farmers are reminded by the U.S. Department of Labor that youngsters under 16 when school is in session, may work only outside school hours as the new school year starts. The reminder is in accordance with the child labor provisions of the Fair Labor Standards Act.

Labor F. Chappell, field office supervisor of the Wage and Hour and Public Contracts Divisions observed, "a youngster's future success depends on the education he obtains today." He added that the "law helps the migrant youngster as well as the local child" and urged the public's cooperation in encouraging young people to return to and stay in school.

The need for continued vigilance is reflected by the Divisions' findings that children who work on farms during school hours in violation of the law are the "ones who really suffer the most." In emphasizing the situation, Chappell pointed out that almost half of the young farm workers were in grades well below the norm for their ages and cited the example that at the age of 15, almost 7 out of 10 of the local youth and 9 out of 10 of the migrants were behind in school grade attainment.

"One cannot remove some of the obstacles of poverty without attaining a modicum of education. That minimum should be at least a high school diploma—without it many of today's opportunities will be closed to our young people," he continued.

Chappell also noted that when state and federal child labor standards differ, the higher standards apply. "The local office of the Wage and Hour and Public Contracts Divisions in the Federal Building, 324 Market Street, Greensboro, N. C. 27402, is ready to assist anyone seeking information about the Fair Labor Standards Act," he added.

**AMA ON MEDICARE FEES**  
The American Medical Association has opposed any move to set up a standard fee schedule for physicians' services in the Medicare program. A spokesman for the AMA said the association favors the usual and customary fee concept under which doctors now bill medicare patients.

# State Office Seekers Are Asking Promises Support

BY: EULA N. GREENWOOD

**ALREADY COMMITTED.....**  
Those people entertaining ideas of running for office next year—be it local or Statewide—have one thing in common.

They are all working now for commitments....promises of support.

"I would really like to be for John Doe—now that he is out—but I am already committed to Richard Roe. I have told John this, and he understands my position."

Hundreds of times the foregoing will be repeated here, there, and everywhere within the next 12 months. And, strange to say, most of the time the person saying it is actually telling the truth.

This is only one of the things anybody planning to oppose Lt. Gov. Bob Scott for Governor in the Democratic Primary must contend with. He has important people in all walks of life already committed to him. This also goes for GOP gubernatorial John Stickle of Charlotte.

**AWAY DOWN.....**The N.C. Good Neighbor Council, recently tremendously strengthened by the Moore Administration, will use part of the new funds to get at the bedrock of possible trouble next summer in North Carolina.

And, furthermore, something they obviously failed to do in Detroit, Newark, and in some other riot areas... this bedrock business.

Virtually all of the groups set up to promote racial harmony have strong, prominent, outstanding Negroes on these committees. But evidence now coming out of some Northern cities shows that they are just as much out of touch—sometimes actually more so—with the lower class Negro as some of the whites. They have made good. Most of them are financially well-to-do. By and large, they are well educated... but frequently far, far away—physically and mentally—from Real Scene.

The Good Neighbor Council plans to employ at a good salary a Negro who has already demonstrated his ability to mingle with the type of persons which started the riots this

summer. He will get away down with the masses—his work takes him there now—when he goes with the Good Neighbor Council. He will find what they are thinking, what their gripes are, and what—if anything—can be done to provide them with sufficient peace of mind to nip blossoming... germs of trouble, Good idea!

**REMOVAL?..** A lot of so-called liberals (frequently they are nothing more than vote-seekers) are now at cross-purposes with Negro leaders. You know who they are... in Washington and elsewhere.

Here is one example of how they stumbled into trouble with the colored people. They talked of ghettos and urban renewal projects. This has usually meant—as it has right here in Raleigh—tearing asunder and literally leveling—slum areas. These districts are usually 90 per cent Negro. But in their eagerness to destroy the so-called ghettos, these dogooders—impractical as usual—forgot to come along with the other solution: provide more places for the uprooted slum-dwellers to go. Moreover, a large percentage of those in the so-called slums loved their little homes, had lived there for generations. It was humble, but it was home. There is—as the song says—no place like home.

The Negro housing situation in many cities of North Carolina is critical. Plans for big conference in Charlotte on Sept. 27. The subject—Housing Problems.

**NEWS BACKGROUND...As of this past Friday (Sept. 8) noon, Downtown Raleigh was a twitter with two news morsels just received:**

1. Former State Sen. Irwin Belk, regarded as a certain candidate for Lt. Gov. on the Democratic ticket, had announced he would not seek the office.

2. The Hotel Sir Walter, known as the center of gravity for political North Carolina, was being given to N.C. State University Foundation.

Everybody was asking what was back of the two moves. The Sir Walter seemed the easier of the two. Velvet Cloak and Voyager Inn—both new and beautiful hotels—are out near State University. Consequently, they—and not the Hotel Sir Walter—have been getting State University visitors.

Being new and in a strategic location, they are getting big day-to-day business. The Sir Walter, deeply down town, has had to depend more and more on conventions—has upwards of 100 big meetings of various kinds already lined up for 1968. This—plus certain tax gimmicks—will be seen as the main reasons for the transfer of ownership. And no change in the management.

Irwin Belk just didn't want to go through with all the trouble necessary to become Lieutenant Governor of this State in 1968! That's it.

Chrysler Corp. ready to build first 1968 models.

# The presses are about to roll

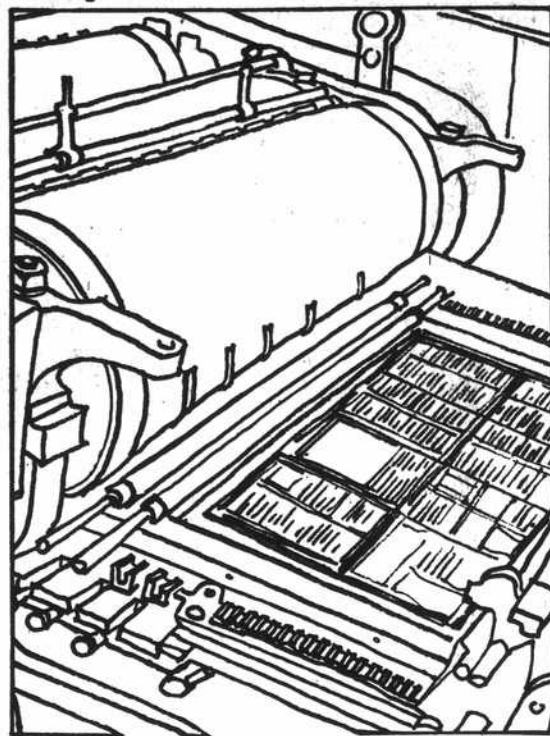

## for the new directory

Time's running out for changes or additions in listings and for Yellow Pages ads! So call our Business Office now.

Additional business or family listings cost just a little.

Are you advertising in the Yellow Pages?—the world's most convenient shopping center! Customers look there first for names, addresses, facts, products and services.



Everything's there in black & yellow

Southern Bell



# On Teaching Staff Of Art School In Chicago

James Moretz, son of Mr. and Mrs. Ralph Moretz of Boone, has been appointed to the teaching staff of the American Floral Art School, Chicago. He assisted at the school eight years ago and has returned as a full-time teacher after gaining more training and experience.

He graduated from the Ohio State University where he majored in floriculture and business administration, aided by a scholarship awarded by the Florists' Transworld Delivery Association. He was a special student teaching-assistant and was elected to Pi Alpha Xi and Gamma Sigma Delta, national honorary fraternities in floriculture and in science. He also

attended the University of the Americas in Mexico City.

In addition to attending the Chicago school several years ago, Jim took lessons in Japanese Ikebana from Mrs. Hoga Fujiwara, leading teacher of the Ohara Center in Tokyo. Coming from an ambitious and hard-working family of 16, he has accomplished much to his credit and is favorably known among leaders of the floral industry. His published articles on floral designing have had wide circulation.

His practical experience includes 10 years of floral designing in leading shops in small towns and larger cities. For the past two years, he has worked in the shop of the Plaza Hotel in New York.



JAMES MORETZ

# Medicare Facts

Under Medicare you can receive help in paying your doctor bills regardless of where you are treated—at home in your doctor's office, or in the hospital.

A Medicare insurance claim must include your itemized receipted bills. These bills should show the dates of treatment, type of treatment and the charge for the particular treatment.

If you work and cannot get to the Hickory Social Security District Office to file a Medicare claim or application to become eligible for Medicare, the office has special hours until 7 P.M. every Friday night.

# SOME PEOPLE DON'T BORROW MONEY.

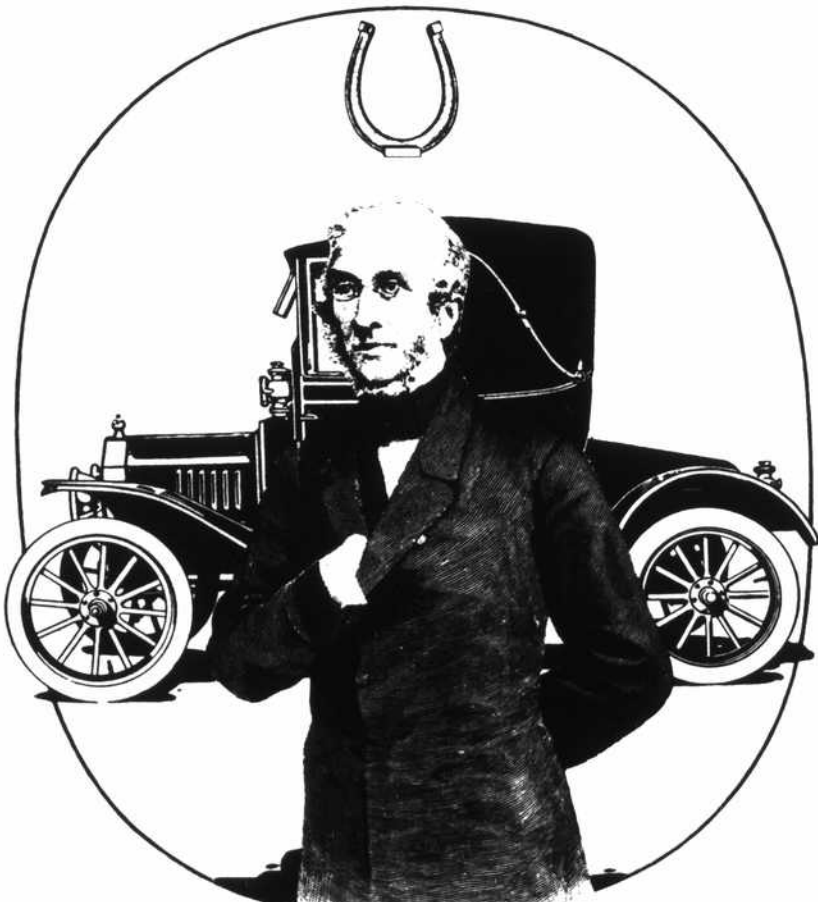

We're not suggesting that you need a new car. As long as you're satisfied with the one you have, keep it and enjoy it. But when it's time to look for something else and money help is needed, remember that The Northwestern Bank offers the most reasonable new car loan in town.

Northwestern's rock bottom interest rate and the easy payment plans are so popular that even old time non-borrowers are slowing down when they drive by.



**THE NORTHWESTERN BANK**

Boone — Blowing Rock

**WHY? GERMAN'S TRAVELERS OUTSOLD**  
At Recent Charlotte Show—  
**Because—**  
German Sells Travel Trailers BUILT RIGHT and PRICED RIGHT  
**GERMAN MOBILE HOMES**  
Granite Falls — Shelby Lenoir  
"More Than A Quarter Century Of Square Dealing"

The Number One Comfort Buy ...

# Warm Morning COAL HEATERS



**MODEL "500" COAL HEATER**



This **\$16.95 BOOSTER FAN** For Only **ONE CENT**  
When You Purchase Either Of These **Warm Morning Cabinet Model Heaters**

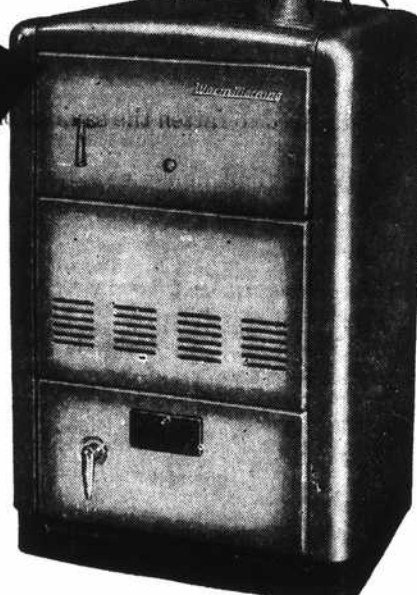

## Warm Morning Has the Features You Want

**MORE HEAT!** From every pound of coal you burn, you get more honest-to-goodness heating comfort. Your WARM MORNING coal heater keeps your home comfortably warm all day and all night. Heats up to 6 rooms.

**LOWER COST!** Because the WARM MORNING makes better use of fuel, it costs you less to operate. Fuel is not wasted. Heat does not go up the chimney before it has had the chance to do its work. You use less fuel with a WARM MORNING.

**LESS WORK!** No more hours spent tending the fire. Just fill your Warm Morning once a day and you get a full day of heating without fuss or bother. Remember you need light a Warm Morning only once a year!

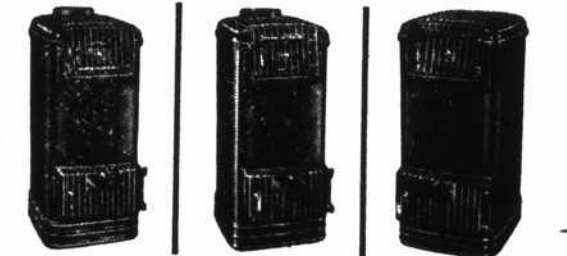

**MODEL 414R:** Smallest heater in the WARM MORNING line... but a big heat producer! Holds 40 lbs. of coal... heats one large or two small rooms. Costs...  
**MODEL 617:** The famous WARM MORNING quality features are combined in the compact radiant Model 617, shown here, which holds 60 lbs. of coal, capably heats 1 to 3 rooms, and costs...  
**MODEL 618:** Has two-tone finish of genuine porcelain enamel. Holds 60 lbs. of coal... heats up to three rooms. A truly deluxe radiant heater for...

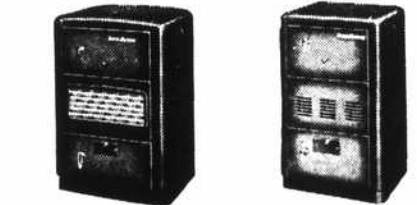

**Model 400**  
WARM MORNING's best... Lifetime porcelain finish, built-in automatic thermostat, large front feed door. Holds 100 lbs. of coal... heats up to 6 rooms. America's greatest coal heater for...  
**Model 460**  
WARM MORNING's popular, budget-priced, medium-size circulator. Handsome cabinet has lifetime porcelain enamel finish, and large front feed door. Holds 60 lbs. of coal... heats up to 4 rooms.

Also Model 818  
And Other **Warm Morning** Coal Heaters For Every Heating Need

We Will Gladly Arrange **Convenient Terms**

# BURGESS FURNITURE STORE

W. King St. 264-3696

Buy Your Warm Morning During September and Get **Free Installation** Plus Free Stove Mat and Free Stove Pipe